

Department of Chemistry and Biochemistry Faculty Research Areas

Pradip K. Bhowmik

- Professor Chemistry, Department of Chemistry and Biochemistry
- Fellow, American Chemical Society
- Fellow, Polymer Chemistry Division
- Ph.D., University of Massachusetts at Amherst
- CHE 207, pradip.bhowmik@unlv.edu
- <http://ww.unlv.edu/chemistry/bhowmik/>



Areas of Expertise

- Organic Chemistry
- Green Chemistry
- Polymer Chemistry
- Materials Chemistry
- Nanostructured Materials
- Anticancer Drugs
- Drugs for Alzheimer's Disease

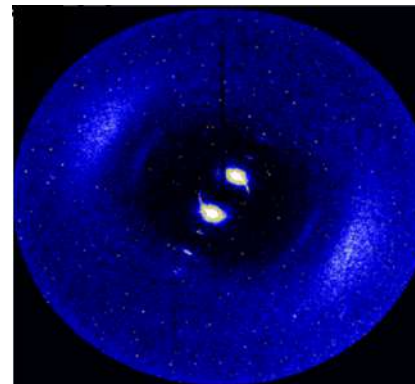

Research Summary:

Bhowmik and his team are developing the following key areas:

- light-emitting and liquid-crystalline ionic polymers for multitude applications in modern technology
- fire retardants polymers
- nanostructured ionic liquids and ionic liquid crystals for advanced functional materials
- organic salts that emit light for sensors, are excellent lubricants and phase change materials
- cisplatin analogs for cancer therapy

Radiochemistry

Paul M. Forster

Department of Chemistry and Biochemistry

Radiochemistry

Expertise:

-Structure determination (X-ray and neutron diffraction, total scattering)

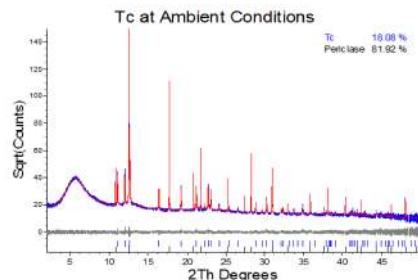
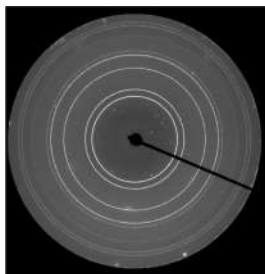
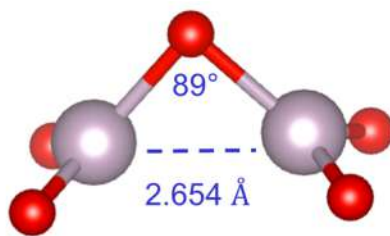
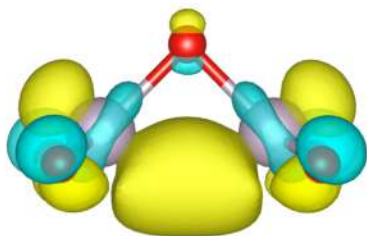

Figure 1 One-hour XRD of technetium metal and magnesium oxide.

-Structure-property relationships, integrated simulation



Probable identification of a gas phase technetium oxide molecule

-Hydro/solvothermal synthesis

Technetium iodide compounds prepared solvothermally

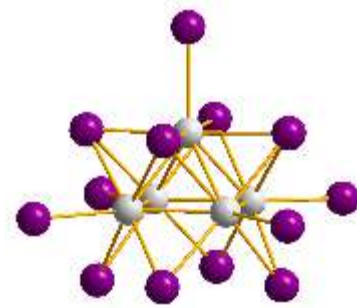
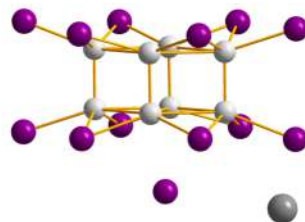

Paul M. Forster

Department of Chemistry and Biochemistry

Radiochemistry

Relevant projects:

First diffraction-based equation of state for elemental Tc

a) EOS of technetium

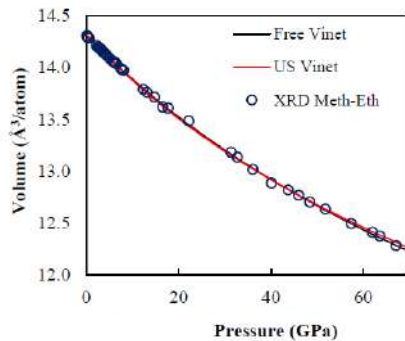

b) EOS of technetium

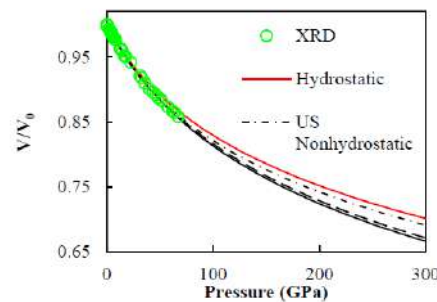

c) Pressure Difference

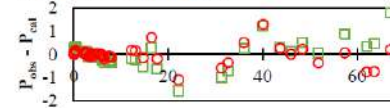

Discovery of new binary Tc nitrides

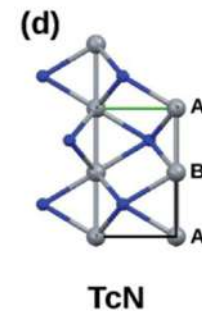
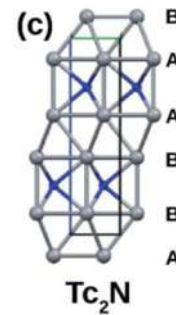
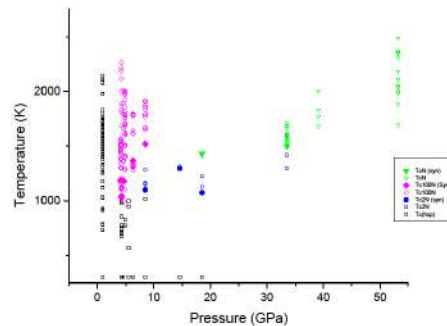

Paul M. Forster
Department of Chemistry and Biochemistry
Radiochemistry

Art Gelis

Director, Radiochemistry Program

Actinide Separations and Recovery

Design and Testing of Advanced Separation Processes using Additive Manufacturing

- Liquid-Liquid Extraction and Separation of Plutonium, Uranium, Minor Actinides, Lanthanides and Fission Products
- Twenty-seven 3D-printed acrylic centrifugal contactors (CC), fabricated at Argonne National Lab are available at UNLV
- Contactors can be 3D-printed in stainless steel or any alloy
- Solvent extraction separations can be tailored to a specific goal
- Example: **Actinide Lanthanide SEP**aration process - **ALSEP**, designed and tested for DOE-NE

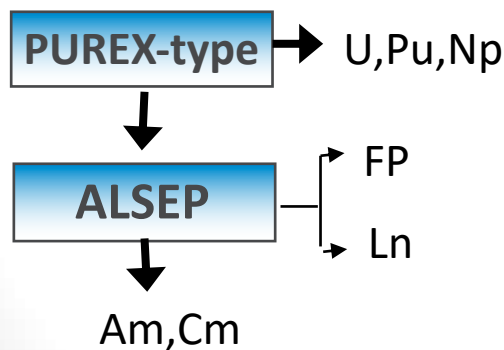

10+1 acrylic CC



Steel CC



Microfluidic Systems for Rapid Radionuclide Separation and Detection

- Microfluidic device to combine aqueous and organic phases, rapidly mix, then separate phases, following by analysis
- Selective Extraction of radionuclides on a very small scale
- Can be implemented either as a bench-top setup or as a portable detector
- Potential applications: rapid Pu separation and detection from Uranium and FP for safeguards; "dirty bomb" analysis

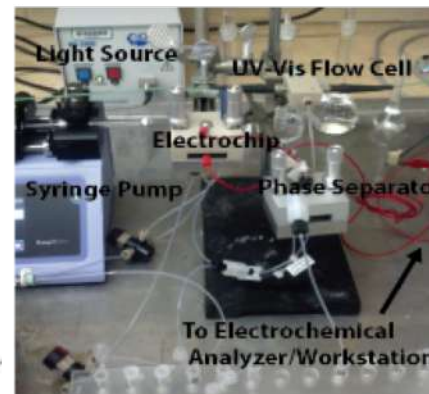
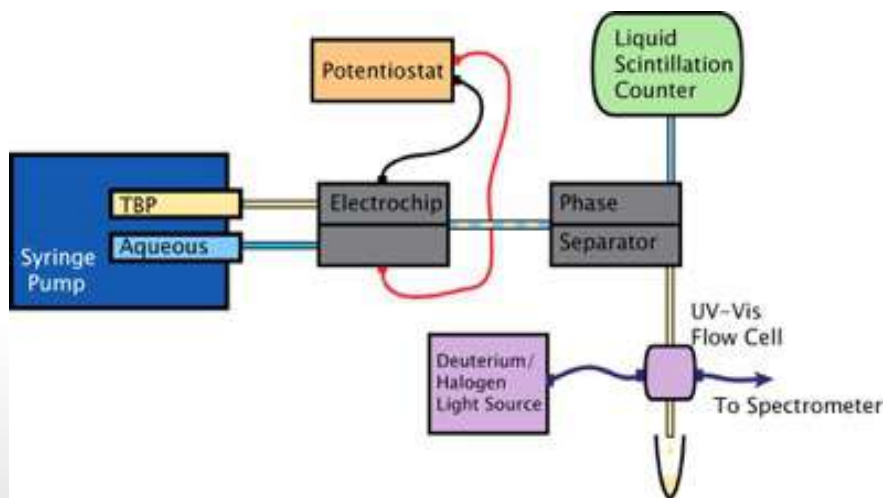
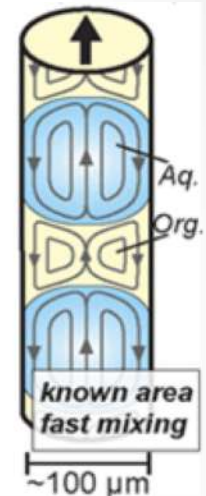

PUBLICATIONS

- Artem V Gelis, Peter Kozak, Andrew T Breshears, M Alex Brown, Cari Launiere, Emily L Campbell, Gabriel B Hall, Tatiana G Levitskaia, Vanessa E Holfeltz, Gregg J Lumetta *Closing the Nuclear Fuel Cycle with a Simplified Minor Actinide Lanthanide Separation Process (ALSEP) and Additive Manufacturing*. **Scientific Reports** volume 9, Article number: 12842 (2019)
- Kevin P. Nichols, Rebecca R. Pompano, Liang Li, Artem V. Gelis and Rustem F. Ismagilov Mechanistic Understanding of Nuclear Reprocessing Chemistries by Quantifying Lanthanide Solvent Extraction Kinetics via Microfluidics with Constant Interfacial Area and Rapid Mixing. *J. Am. Chem. Soc.*, 2011, 133 (39), 15721–15729.
- Artem V. Gelis and Gregg J. Lumetta. Actinide Lanthanide Separation Process—ALSEP. *Ind. Eng. Chem. Res.*, 2014, 53 (4), pp 1624–1631
- M. Alex Brown, Alena Paulenova, and Artem V. Gelis Aqueous Complexation of Thorium(IV), Uranium(IV), Neptunium(IV), Plutonium(III/IV), and Cerium(III/IV) with DTPA. *Inorg. Chem.*, 2012, 51 (14), 7741–7748
- Gelis, A. V., Vandegrift, G. F., Bakel, A., Bowers, D. L., Hebden, A. S., Pereira, C., & Regalbuto, M. (2009). Extraction behaviour of actinides and lanthanides in TALSPEAK, TRUEx and NPEX processes of UREX+. *Radiochimica Acta*, 97(4–5). <https://doi.org/10.1524/ract.2009.1601>
- Gelis, A.V., Pereira C, Nichols, K. Microfluidic process monitor for industrial solvent extraction system. US Patent # 9233859
- Gelis A.V. - Actinide and lanthanide separation process (ALSEP) US Patent 8,354,085, 2013
- [More @google scholar profile https://scholar.google.com/citations?user=0C7sSjMAAAAJ&hl=en](https://scholar.google.com/citations?user=0C7sSjMAAAAJ&hl=en)

Strategic Materials Analysis and Recovery – David Hatchett and Ken Czerwinski

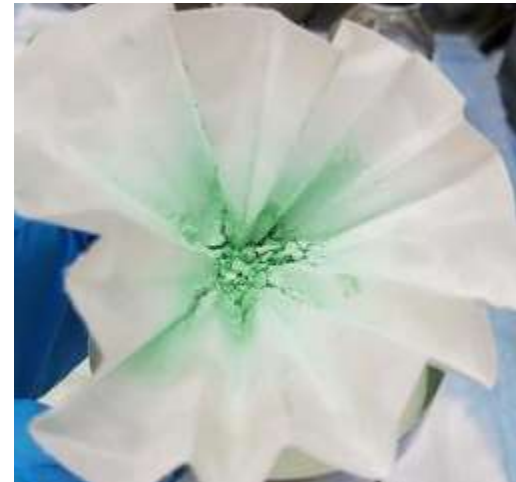

Dissolution of UF_6 into IL at 0 hours, 24 hours, 30 days, and the recovery of UF_6 salt.

Expertise:

- Actinide, Lanthanide, and Li materials recovery from Ionic Liquids (ILs).
- Electrochemical, Spectroscopic, and thermal analysis of Radioactive materials.
- Radiochemistry and Analytical Chemistry.

Strategic Materials Analysis and Recovery – David Hatchett and Ken Czerwinski

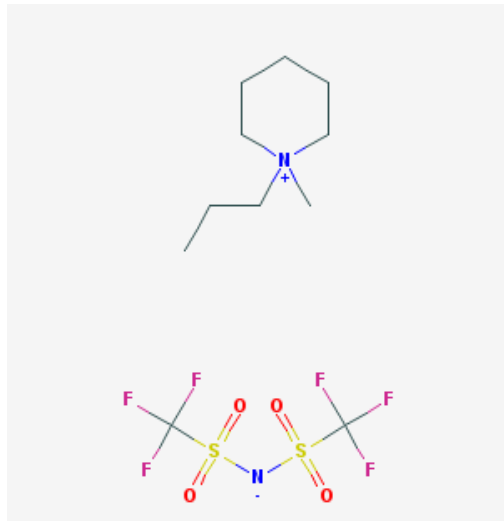

1-methyl-1-propyl piperidinium
bis(trifluoromethylsulfonyl)imide
[MPPi][TFSI]

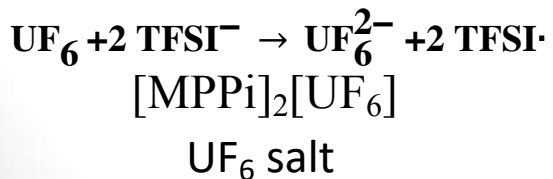

Electrochemistry



Low Concentration
0.1 M

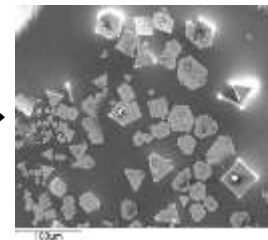

U metal
Crystallites

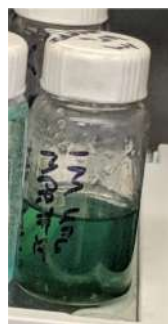

High Concentration
0.95 M



UF₆ salt

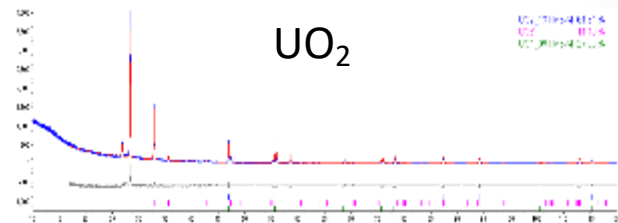

Air
U metal

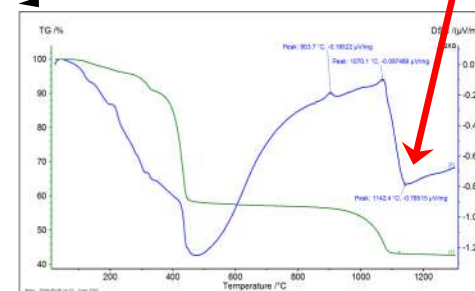

Paths to U recovery from UF₆ dissolved in IL

Surface and Interface Characterization of Materials for Energy Conversion

Dr. Clemens Heske

Professor

Department of Chemistry and Biochemistry

heske@unlv.nevada.edu

Expertise

- Electronic and Chemical Structure of Energy-Conversion Materials
- Surface and Interface Characterization
- Soft x-ray and Electron Spectroscopy
- Scanning Probe Microscopy
- Synchrotron Radiation

Surface and Interface Characterization

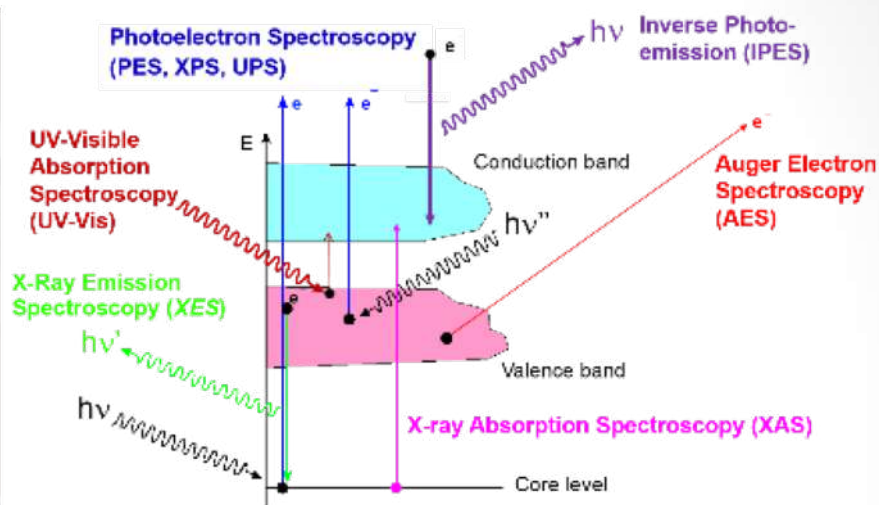
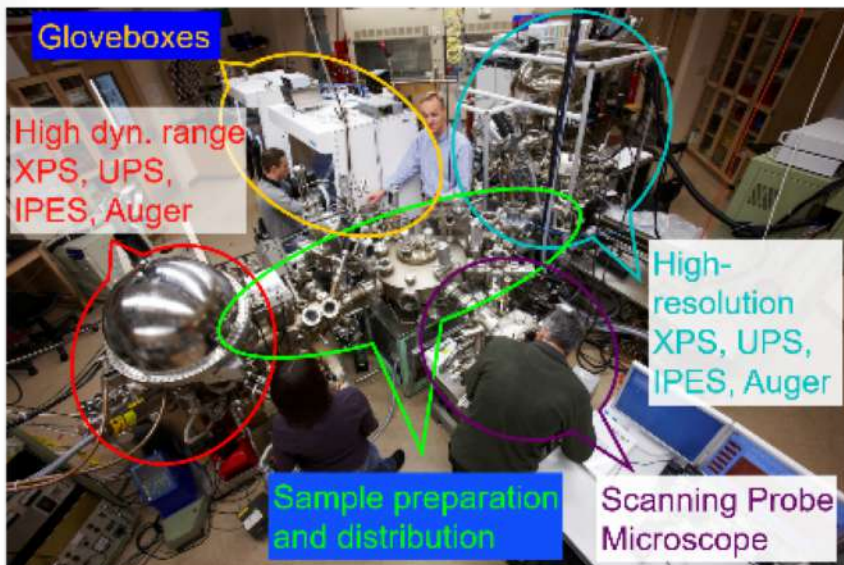

SALSA: Solid And Liquid Spectroscopic Analysis

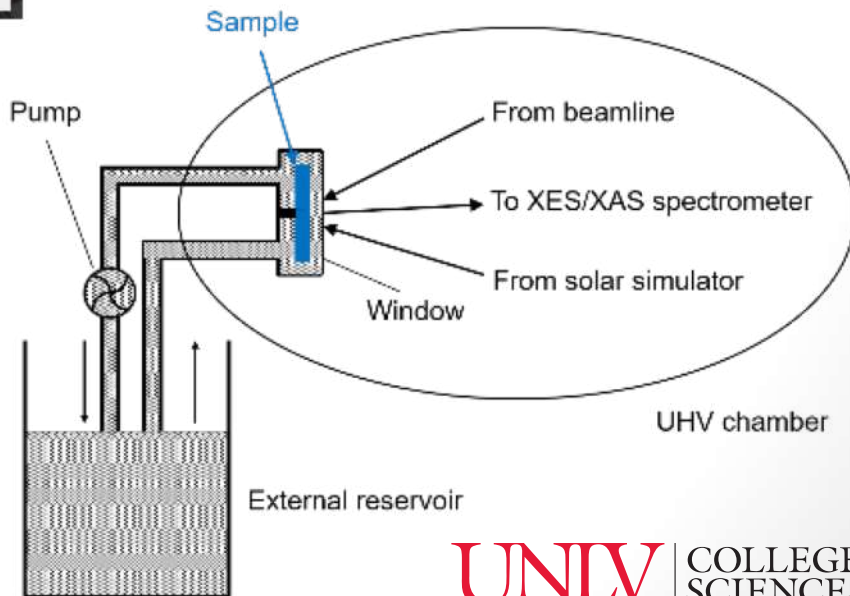
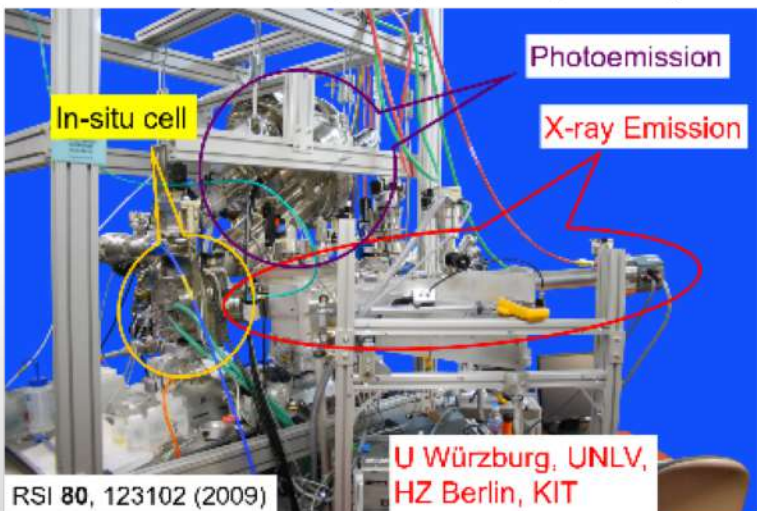

Materials for Energy Conversion

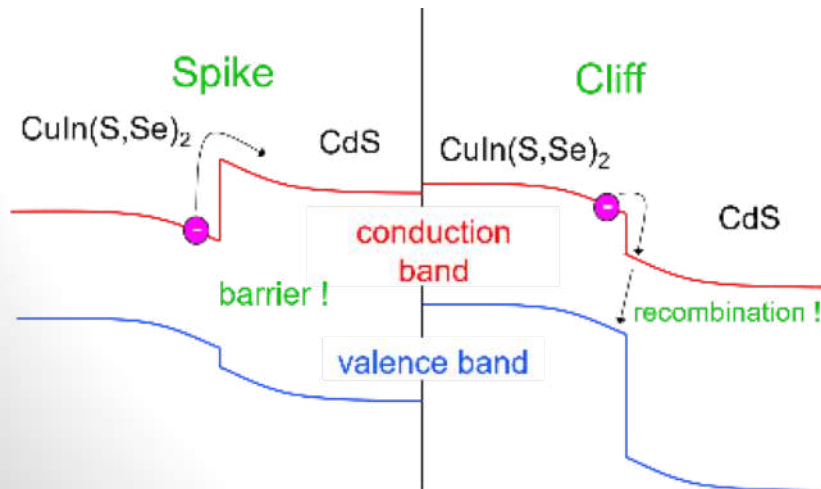
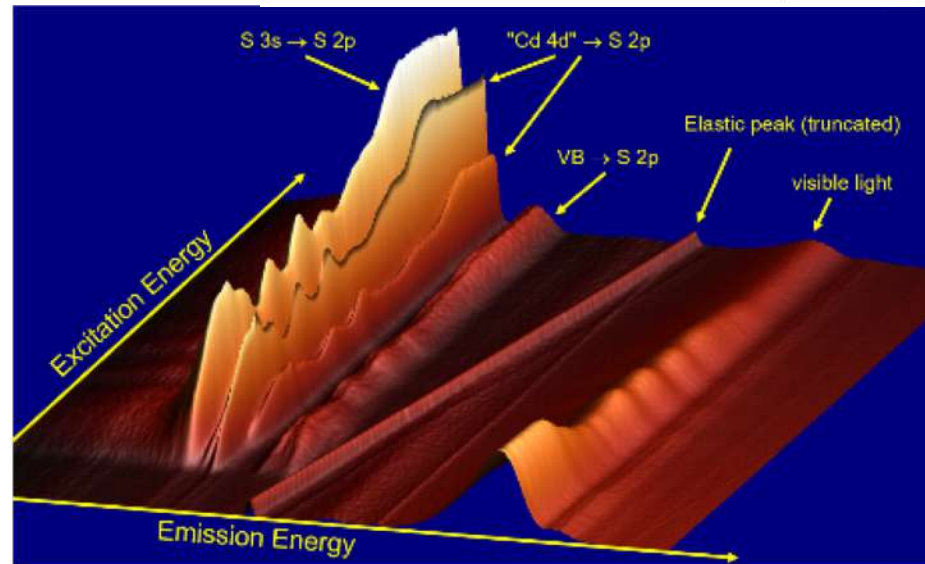
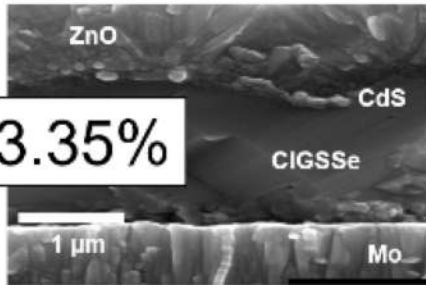
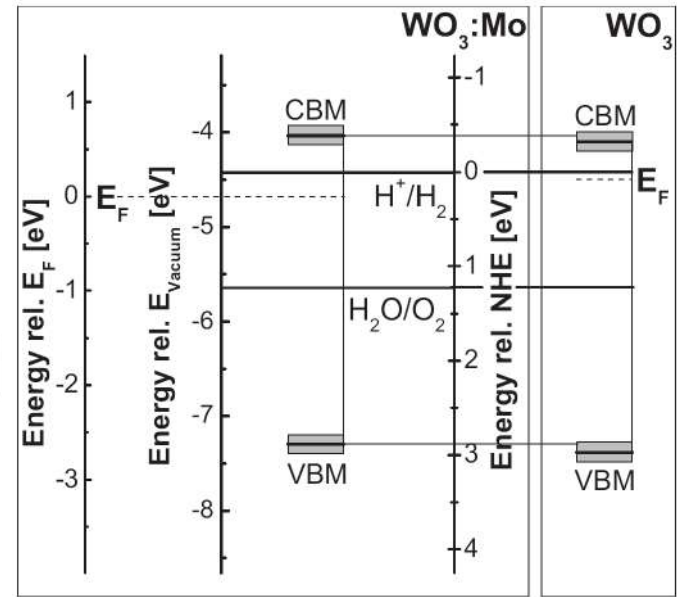
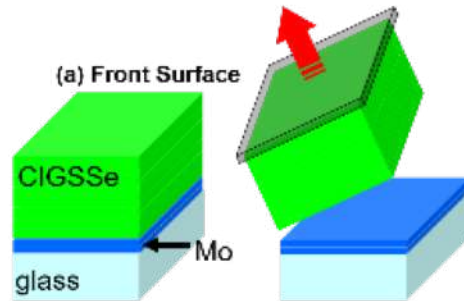

Jun Yong Kang

- Assistant Professor, Department of Chemistry and Biochemistry
- Ph.D., Chemistry, Texas A&M University, College Station, TX
- CHE 217B, junyong.kang@unlv.edu
- http://jkang.faculty.unlv.edu/?page_id=110

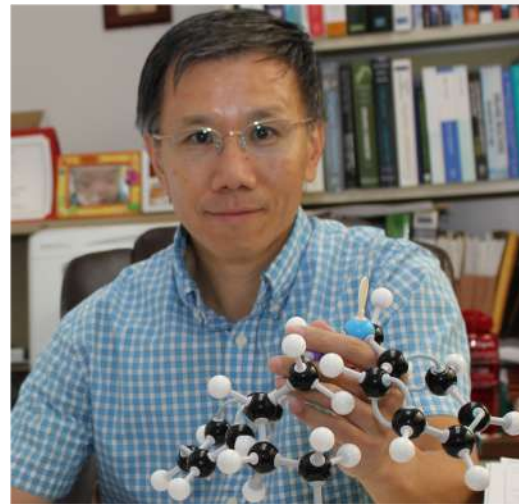

Areas of Expertise

- Synthetic organic chemistry
- Development of new synthetic methodology
- Asymmetric organocatalysis
- Organophosphorus chemistry
- Synthesis of bioactive small molecules

Research Summary:

The development of new synthetic methodologies plays a key role in medicinal chemistry, biochemistry, and materials chemistry. Professor Kang and his group have been developing novel synthetic transformation and new chemical reagents such as commercially available NHP-thiourea and NHP-butane to apply for pharmaceuticals and bioactive molecules.

Kang's reagents-commercially available at Kerafast

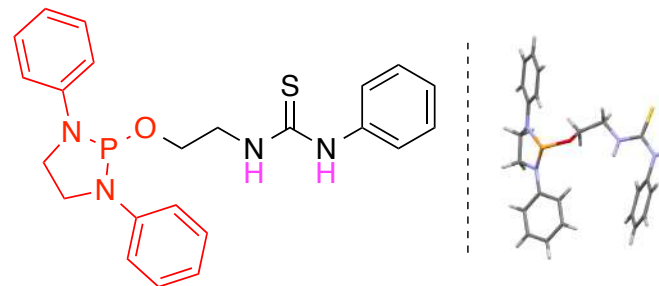

NHP-thiourea
(phosphonylation reagent)

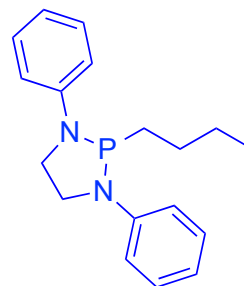

NHP-butane
(organocatalyst)

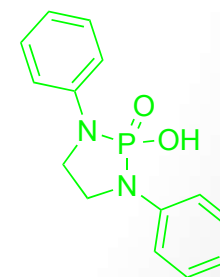

NHPA
(organocatalyst)

Ubiquitin-mediated protein degradation

Dr. Gary Kleiger

Associate Professor

Department of Chemistry and Biochemistry

gary.kleiger@unlv.edu

Expertise

- Structural biology
- Proteomics
- Enzyme kinetics and biophysical assays
- Cell biology

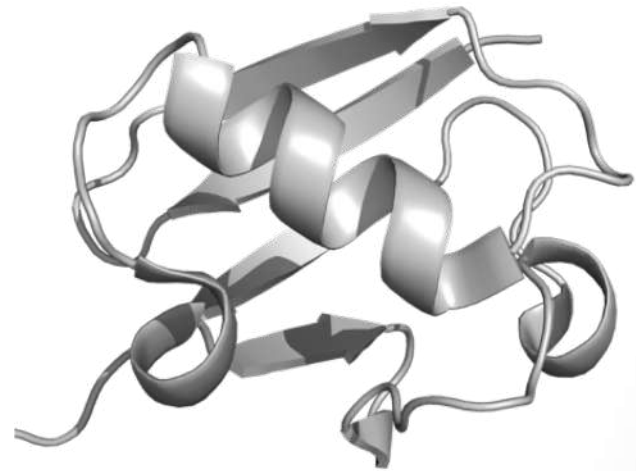

Protein structure of Ubiquitin.

Uncovering how the enzymes that promote protein degradation function in human cells.

Kinetics help us understand how enzymes select protein targets for modification with ubiquitin.

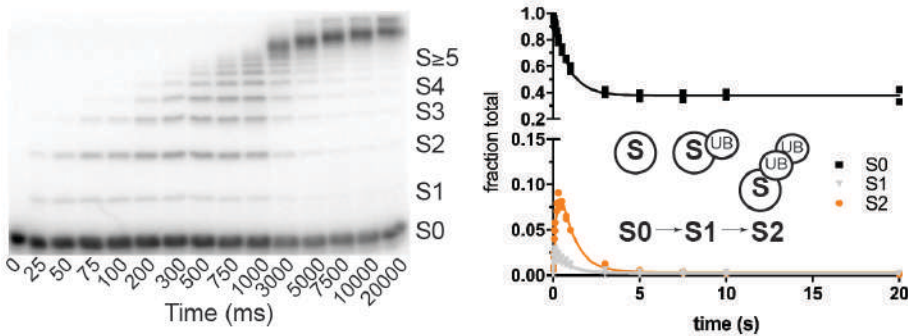

High-resolution mass-spectrometry tells us how mutations in enzymes that lead to human disease affect the stabilities of key human cellular proteins.

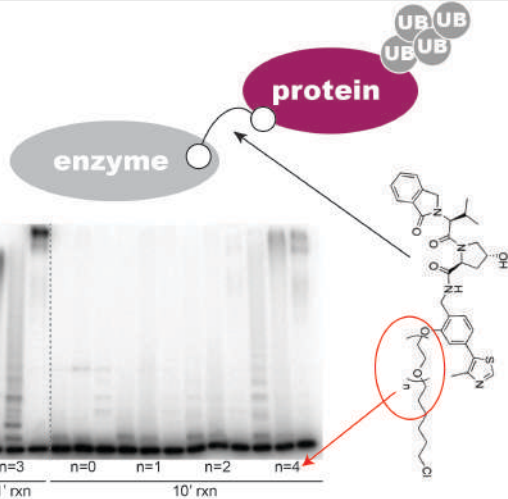
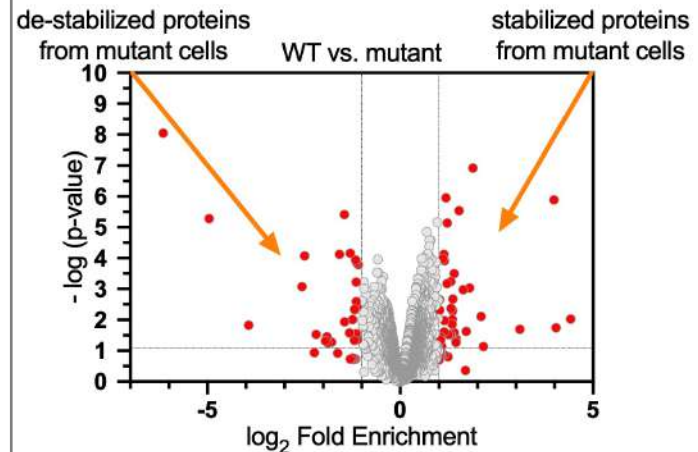

Small molecule inducers of protein degradation can be used to treat human disease. We study the mechanism of how they function both in test tubes and cells.

The Kleiger lab partners with both industry and academic labs to help discover treatments for human diseases such as cancer.



Mass-spec proteome exploration with Dr. Don Kirkpatrick at Genentech Inc.



How to utilize small molecules to induce the degradation of disease-causing proteins with Dr. Craig Crews (Yale and founder of Arvinas Inc.).



Cryo-EM and structural biology with Max Planck Institute of Biochemistry Director Dr. Brenda Schulman.

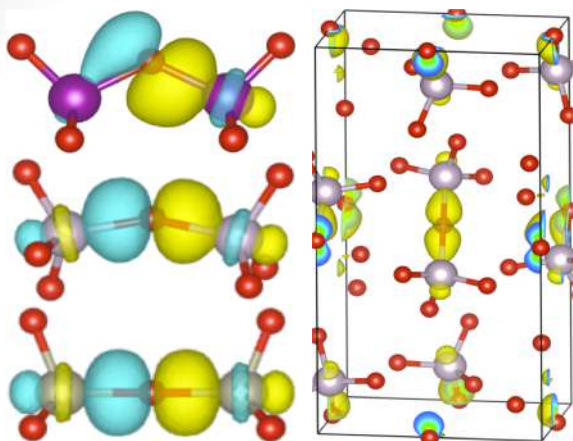

Electronic structure simulations of the bonding and properties of compounds synthesized by the team.

Molecular dynamics to understand the thermal behavior of materials and melts. *Supporting Salamat's high temperature experimental goals.

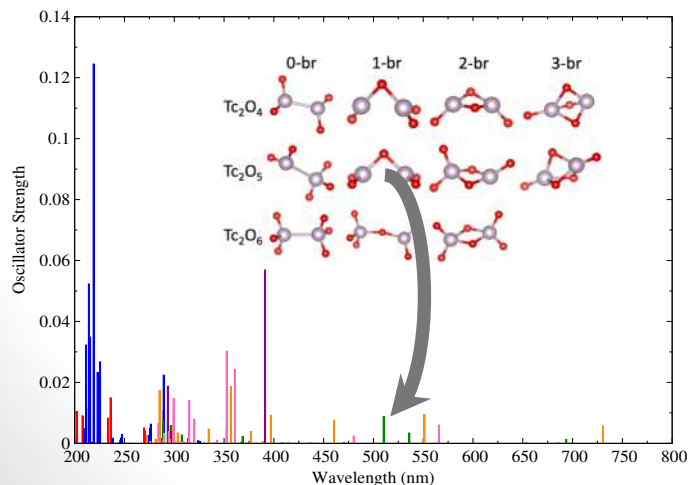
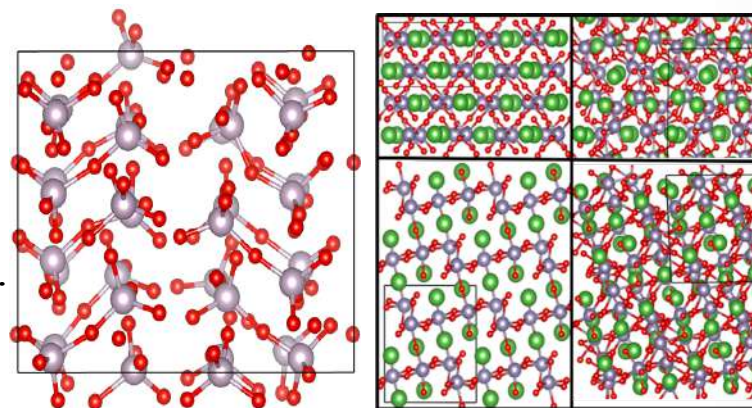

Automated molecular structure screening and simulated spectroscopy to understand speciation during reactions, ie. the reduction of TcO_4^- during vitrification.

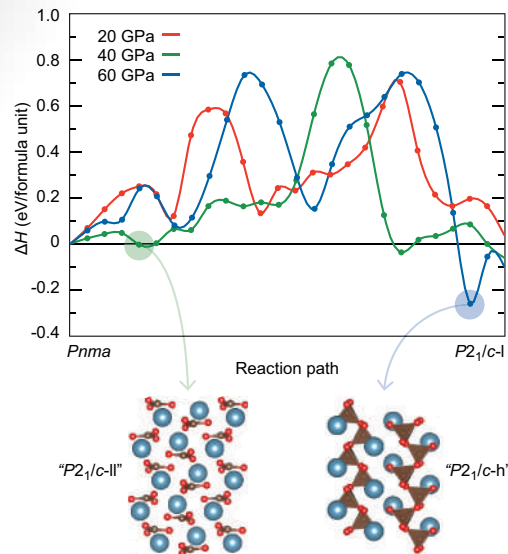

Identifying new phases of materials and the transition pathways connecting them. Thus far targeting geological or wastefrom problems.

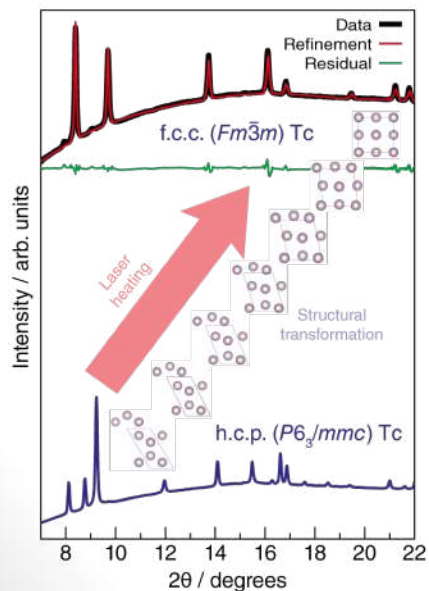
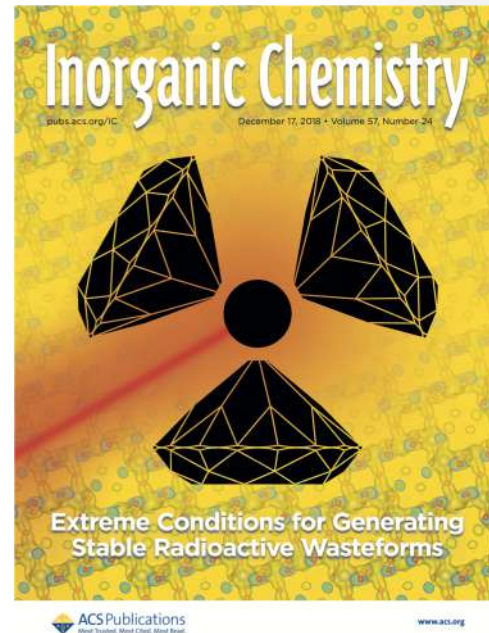

Currently looking for new nitrides, sulfides and hydrides (especially of Tc) as well as developing reactive force fields for metals to expedite materials discovery by targeting both pressure and temperature conditions.

Organic Materials Chemistry

Dong-Chan Lee, Ph.D.

Associate Professor

Department of Chemistry & Biochemistry

Phone: 702-895-1486

Email: dong-chan.lee@unlv.edu

Expertise

- Organic semiconductors with tunable electronic properties
- Self-assembly (nanomaterials, organogels, etc.)
- All organic room-temperature phosphors
- Materials development for solid-state emission with high quantum yield

Electronic-Property Tuning with Smart Molecular Design

E_{LUMO} -3.16 eV

-3.26 eV

-3.22 eV

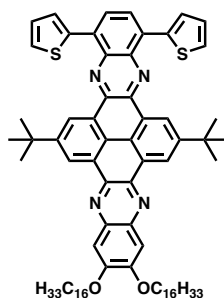
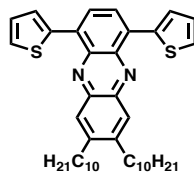
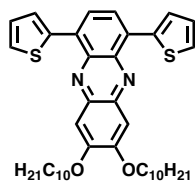

-3.89 eV

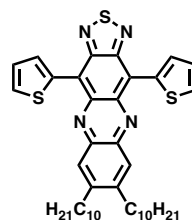

-3.80 eV

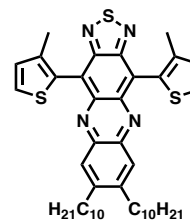

-3.84 eV

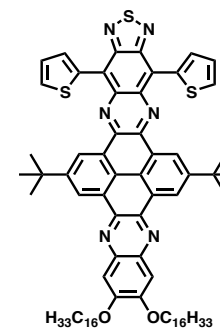

E_{HOMO} -5.43 eV

-5.45 eV

-5.49 eV

-5.32 eV

-5.51 eV

-5.40 eV



Solvent-Dependent Morphology Control through Organogelation

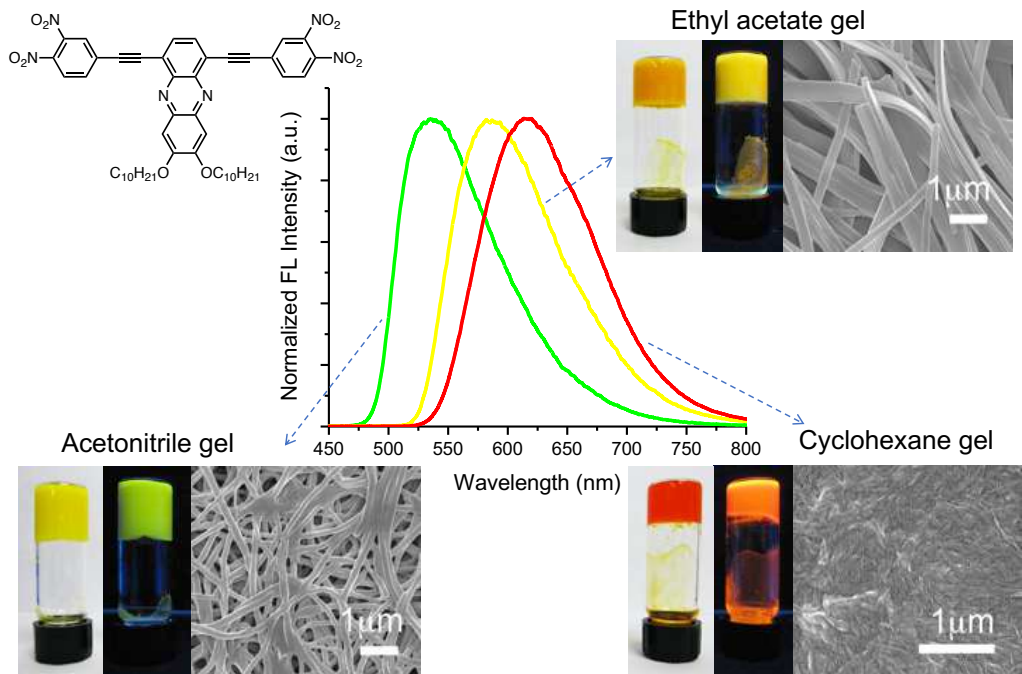

Journal of Materials Chemistry



Solid-State
Emission with
High
Quantum
Yield

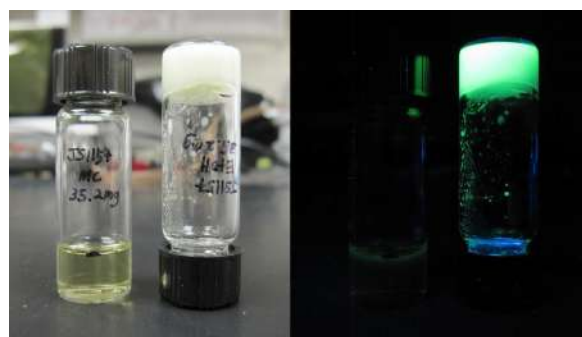

Gel-Induced
Room
Temperature
Phospho-
rescence

Quantum Information and Quantum Control of Chemical Reactions

Balakrishnan Naduvalath

Department of Chemistry & Biochemistry,
UNLV

Areas of Expertise

- Ultracold Molecules
- Ultracold Quantum Engineered Chemistry
- Quantum control of chemical reactions
- Geometric phase effect in chemistry
- Stereodynamic control of chemical reactions

\$\$\$: NSF, DOD, NASA

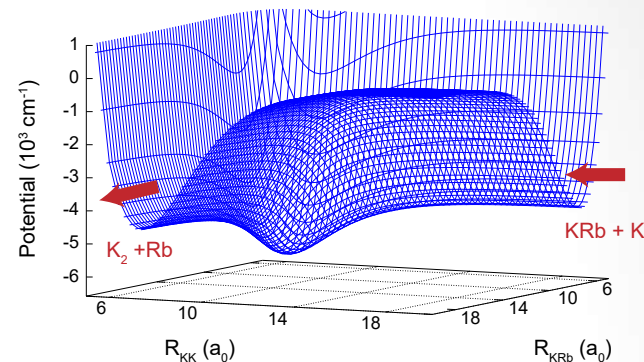

Chemical reaction pathway in ultracold $K+KRb$ collisions. Quantum engineered KRb molecules have been prepared at 300 nK. Ultracold polar molecules such as KRb are potential candidates for quantum computing and quantum information processing.

Controlling reaction outcome through quantum interference

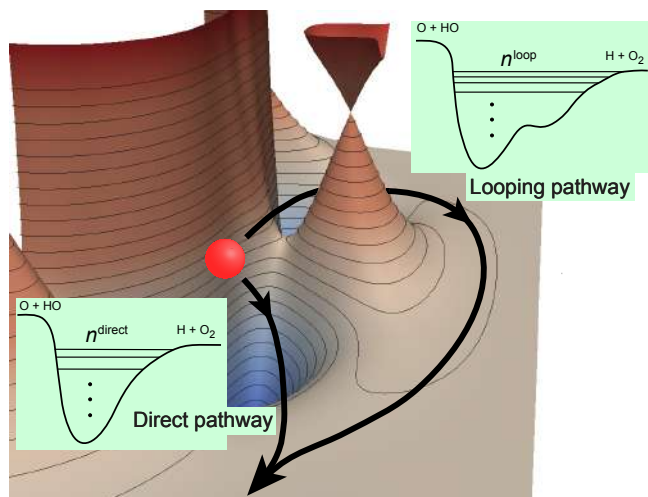

Right panel: The nature of the interference can be controlled by including “geometric phase”. In the image on the right, inclusion of the geometric phase enhances the reactivity. The geometric phase (that correctly describes the sign of the wave function near a conical intersection with an excited electronic state) acts as a “quantum switch” (Hazra, Balakrishnan, and Kendrick, *J. Phys. A* **119**, 12291 (2015))

Left panel: Two paths for a chemical reaction. These two paths can interfere constructively or destructively, maximizing or minimizing the reaction rate. This quantum effect becomes magnified in the ultracold regime (Kendrick, Hazra, and Balakrishnan, *Nature Comm.* **6**, 7918 (2015)).

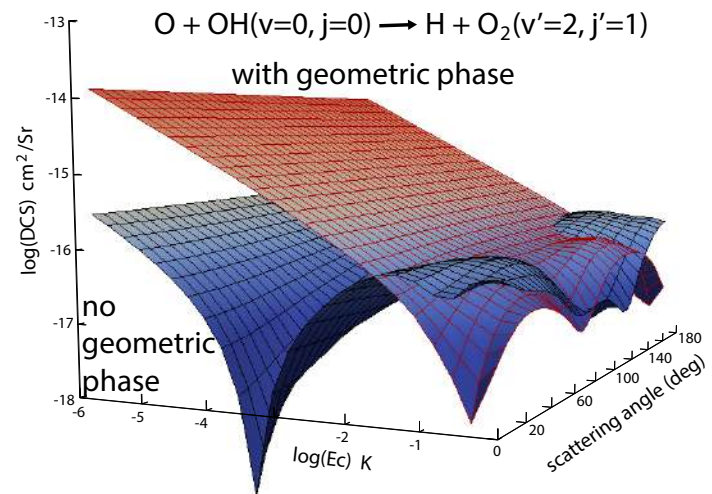

References

- P. G. Jambrina, J. F. E. Croft, H. Guo, M. Brouard, N. Balakrishnan, and F. J. Aoiz, Stereodynamical control of a quantum scattering resonance in cold molecular collisions, *Phys. Rev. Lett.* **123**, 043401 (2019).
- J. F. E. Croft and N. Balakrishnan, Controlling rotational quenching rates in cold molecular collisions, *J. Chem. Phys.* **150**, 164302 (2019).
- K. Hilsabeck, J. Meiser, M. Sneha, N. Balakrishnan, and R. N. Zare, Photon Catalysis of Deuterium iodide photodissociation, *Phys. Chem. Chem. Phys.* **21**, 14195 (2019).
- J. F. E. Croft, N. Balakrishnan, M. Huang, and H. Guo, Unrevealing the stereodynamics of cold controlled HD-H₂ collisions, *Phys. Rev. Lett.* **121**, 113401 (2018). (**Editor's choice**).
- J. F. E. Croft, C. Makrides, M. Li, A. Petrov, B. K. Kendrick, N. Balakrishnan, and S. Kotochigova, Universality and chaoticity in ultracold K+KRb chemical reactions, *Nature Comm.* **8**, 15897 (2017).
- N. Balakrishnan, Perspective: Ultracold molecules and the dawn of cold controlled chemistry, *J. Chem. Phys.* **145**, 150901 (2016).
- B. K. Kendrick, J. Hazra, and N. Balakrishnan, The Geometric Phase Appears in the Ultracold Hydrogen Exchange Reaction, *Phys. Rev. Lett.* **115**, 153201 (2015).
- B. K. Kendrick, J. Hazra, and N. Balakrishnan, The Geometric Phase Controls Ultracold Chemistry, *Nature Communications* **6**, 7918 (2015).

MaryKay Orgill

Professor

Department of Chemistry and Biochemistry

- Ph.D., Chemistry, Purdue University
- Fellow, Royal Society of Chemistry
- Former Chair of the American Chemical Society Division of Chemical Education
- CHE 116, MaryKay.Orgill@unlv.edu
- <https://www.unlv.edu/people/marykay-orgill>

Areas of Expertise

- Chemistry Education
- Biochemistry Education

Research Summary:

I am interested in using qualitative research techniques to examine and improve undergraduate chemistry teaching and learning. Currently, this involves looking at how students understand concepts explained in chemistry classes, how they solve chemistry-related problems, how they visualize different chemical concepts, and how they use language to make sense of chemical concepts. I have also been involved in a number of projects that provide professional development opportunities to faculty and K-12 teachers



→ Synthetic and coordination chemistry

Technetium binary and ternary halide compounds

Compounds with multiple metal-metal bonds

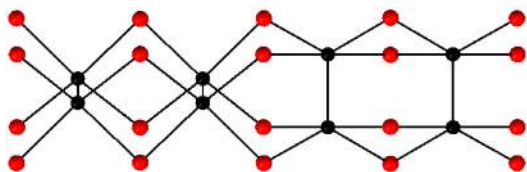

TcCl_2 : a unique structure-type

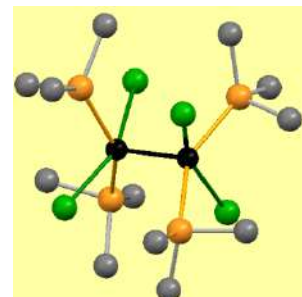

$\text{Tc}_2\text{Cl}_4(\text{PMe}_3)_4$

→ Chemistry relevant to remediation and fuel cycle applications

Separation, vitrification, and waste forms (alloys)



Demonstration of the separation of uranium from technetium for fuel cycle application

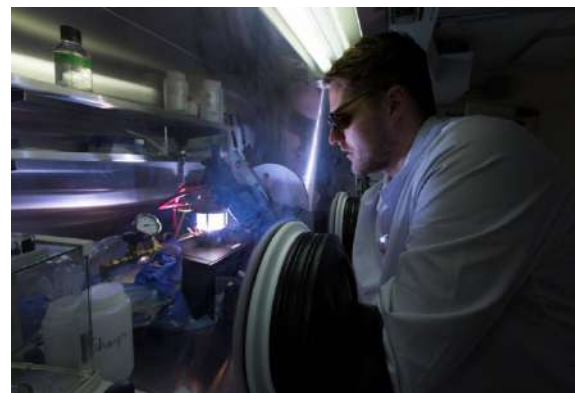

Preparation of U-Tc alloys by arc melting

→ Collaborative work relevant to nuclear forensics

Analysis of Uranium Isotopic Ratios by Thermal Ionization Mass Spectrometry (TIMS)

- Uranium compounds found throughout the fuel cycle (UO_2 , U_3O_8 , UF_4) prepared at UNLV
- $^{235}\text{U}/^{238}\text{U}$ isotopic ratio measurements using TIMS at LANL

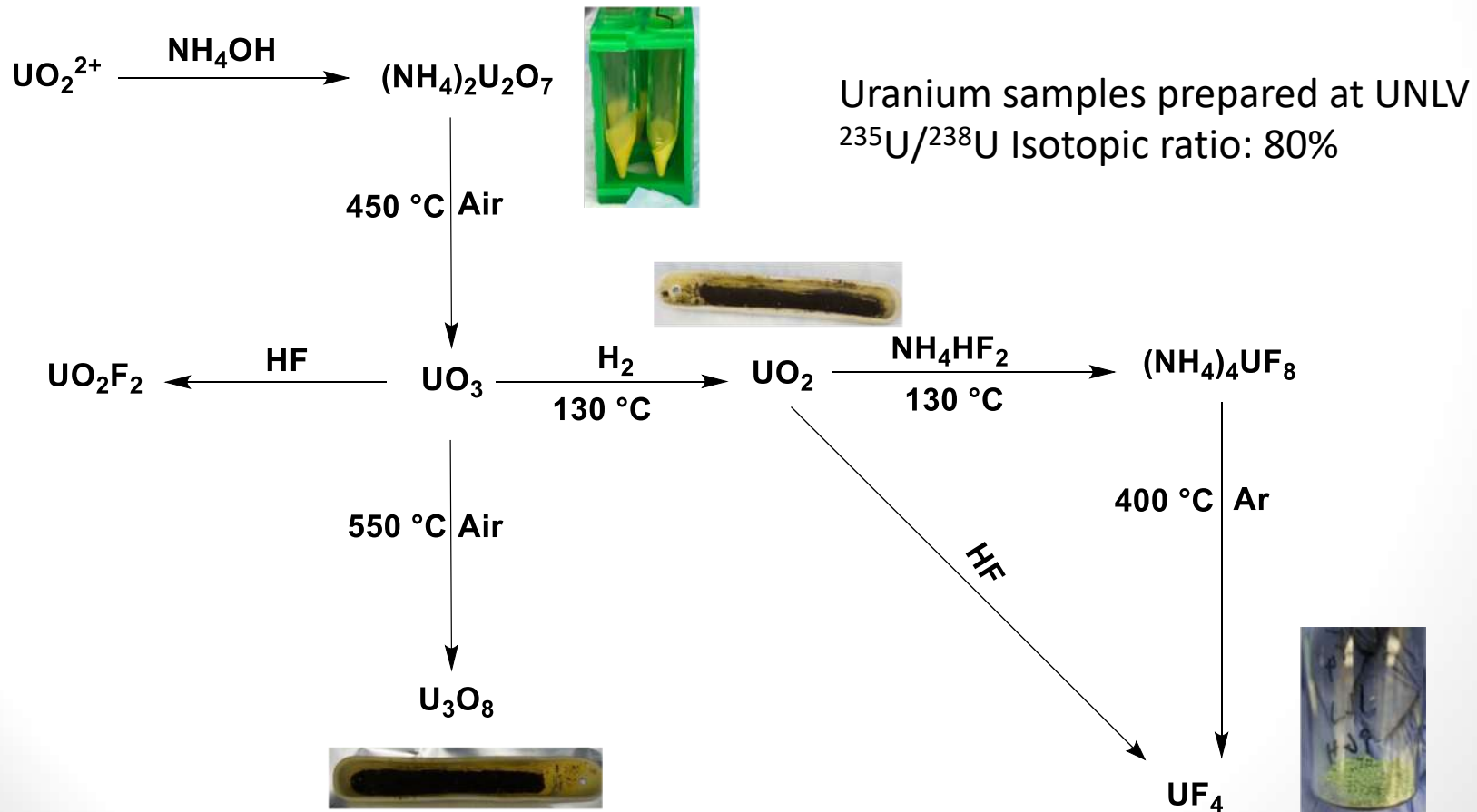

Electrochemistry and Spectroelectrochemistry in molten salts for the development of the molten salt nuclear reactor

- Fundamental redox and thermodynamic properties of nuclear fuel can be gained using electrochemistry and spectroelectrochemistry.
- Diamond electrodes are specifically amenable to use as the sensing material due to its robustness and tunable properties

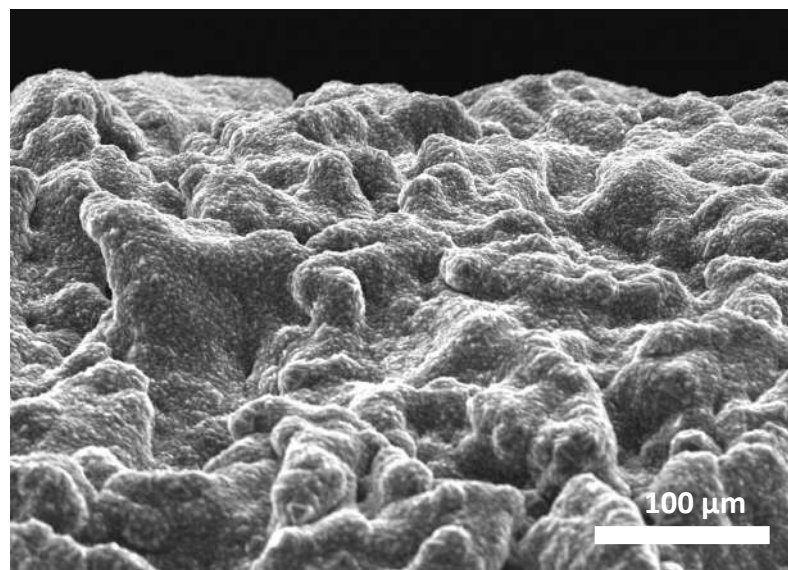
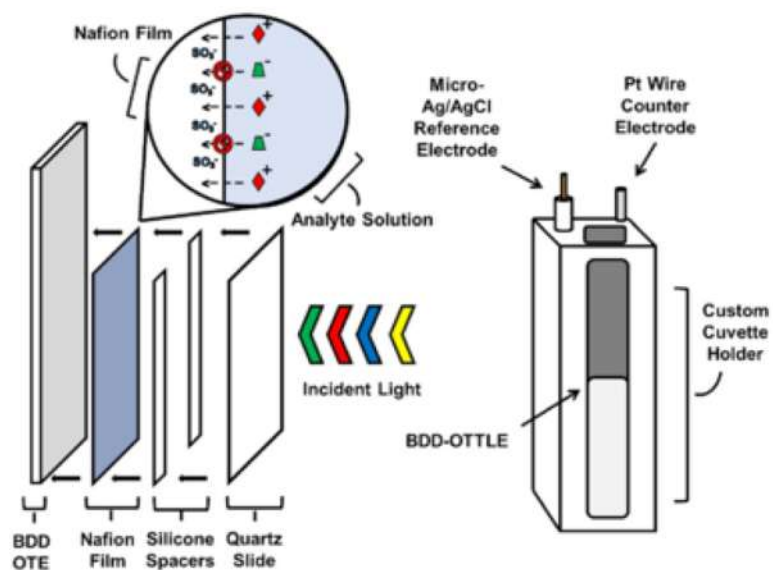

SEM image of diamond film

Detection of clinically- and environmentally-relevant analytes with electrochemical sensors

- The all-diamond microfiber electrodes are a supremely biocompatible electrode. With the advantageous properties of diamond electrodes, the suite of potential analytes is expanded.
- The conductive BDD core is covered along the shank with undoped diamond, thereby making the device non-reactive.
- The batch-fabricated nature of these devices make them attractive compared to others.

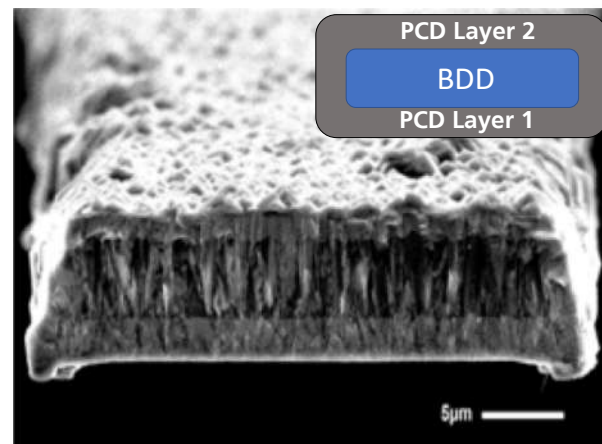
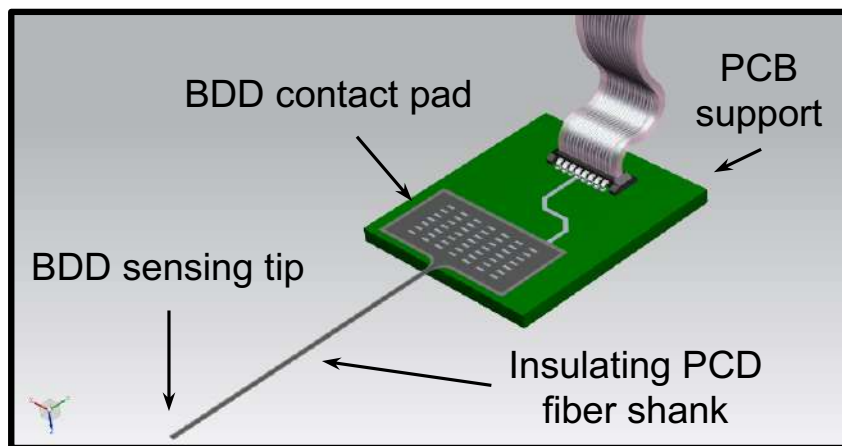

Publication track record

“Polymer-coated Boron Doped Diamond Optically Transparent Electrodes for Spectroelectrochemistry” C.A Rusinek, M. Becker, R. Rechenberg, D. Zhao, K. Ojo, N. Kaval, and W.R. Heineman. *Electroanalysis*, 2016, 28, 2228-2236.

“Fabrication and characterization of boron doped diamond microelectrode arrays of varied geometry” C.A Rusinek, M. F. Becker, R. Rechenberg, T. Schuelke, *Electrochemistry Communications*, 2016, 73, 10-14

“Large-scale, All Polycrystalline Diamond Structures Transferred on Flexible Parylene-C Films for Neurotransmitter Sensing” B. Fan, Y. Zhu, R. Rechenberg, C.A Rusinek, M.F. Becker, W. Li, *Lab-on-a-Chip*, 2017, 17, 3159-3167.

“Isatin Detection using an All Boron-doped Diamond 3-in-1 Sensing Platform” M. Ensich, V.Y. Maldonado, G. M. Swain, R. Rechenberg, M.F. Becker, T. Schuelke, C.A Rusinek, *Analytical Chemistry*, 2018, 90, 1951-1958.

“Analysis of Ag(I) Biocide in Water Samples using Anodic Stripping Voltammetry with a Boron-doped Diamond Disk Electrode” V.Y. Maldonado, P.J. Espinoza, C.A Rusinek, G.M. Swain, *Analytical Chemistry*, 2018, 90 (11), 6477–6485.

“All Diamond Microfiber Electrodes for Neuroelectrochemistry” C.A Rusinek, Y. Guo, R. Rechenberg, E. Purcell, C. McKinney, M.F Becker, W. Li, *Journal of the Electrochemical Society*, 2018, 165 (12), G3087-G3092.

“Indium Tin Oxide Film Characteristics for Cathodic Stripping Voltammetry” M. Ensich, B. Wehring, G.D Landis, M.F Becker, T. Schuelke, C.A Rusinek, *ACS Applied Materials and Interfaces*, 2019, 11 (18), 16991-17000.

“Determination of Lead with a Copper-Based Electrochemical Sensor” W. Kang, X. Pei, C.A Rusinek, A Bange, E.N Haynes, W.R Heineman, I. Papautsky. *Analytical Chemistry*, 2017, 89, 3345-3352.

Google Scholar:

<https://scholar.google.com/citations?user=uZyA2VUAAAAAJ&hl=en&authuser=1>

Biochemistry – Interrogate Cell Signaling Pathways by Molecular, Genetic and Proteomic Approaches

Dr. Hong Sun

Associate Professor

Department of Chemistry and Biochemistry

Telephone: (702) 774-1485

Email: hong.sun@unlv.edu

Expertise

- Cell signaling
- Cancer cell biology
- Stem cell biology
- Mouse conditional knockout models

Regulation of cell surface receptor RTKs localization and activation

Problem: cancer cells often have multiple receptors (RTKs) activated on cell surface, making targeting inefficient

Co-activation of AXL-MET RTKs: HGF (ligand for MET) also activates AXL, detected by antibodies for p-AXL-Y779

A novel mechanism discovered for RTK-Co-activation and signaling for cancer cell migration and invasion

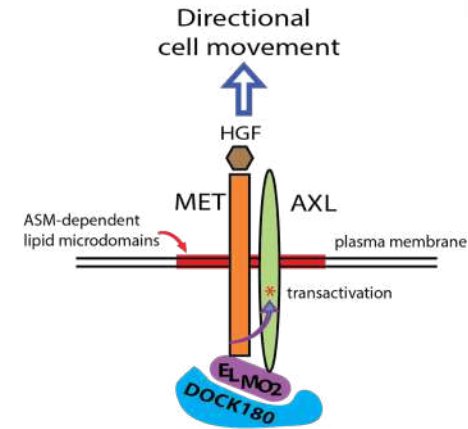
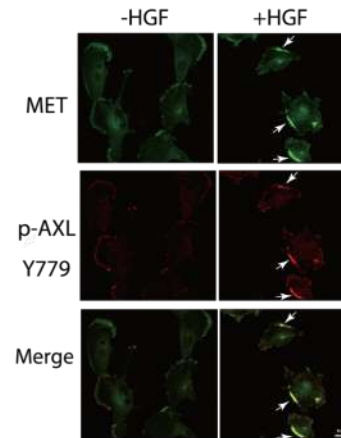
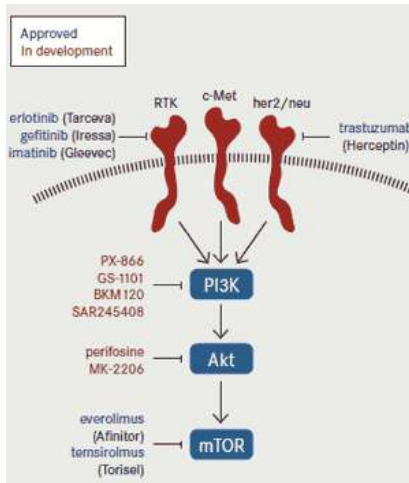

Li et al., J. Biol. Chem. (2018) 293:15397-15418.

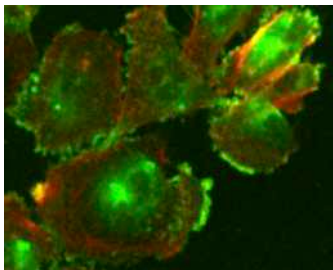

Vehicle

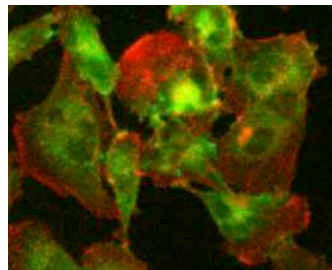

ASM Inhibitor

ASM inhibition prevents the MET RTK to be transported to the cell surface, as revealed by immunostaining (MET, green label; and a control cell surface protein, red label).

Zhu et al, J. Cell Science (2016) 129, 4238-4251.

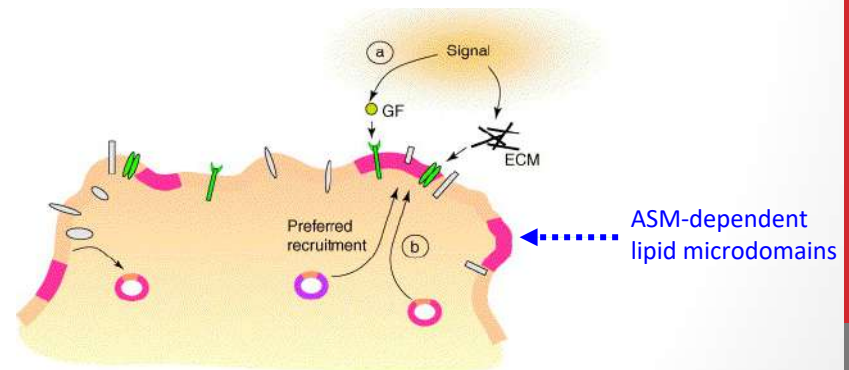

Mass-Spectrometry analyses revealed that the ASM-regulated local lipid microdomains were enriched with many signaling molecules.

Xiong et al. Biol. Open (2019) 8, bio040311.

Regulation of stem cell maintenance: insights from the genetic studies in novel mouse knockout models

A. Gene locus

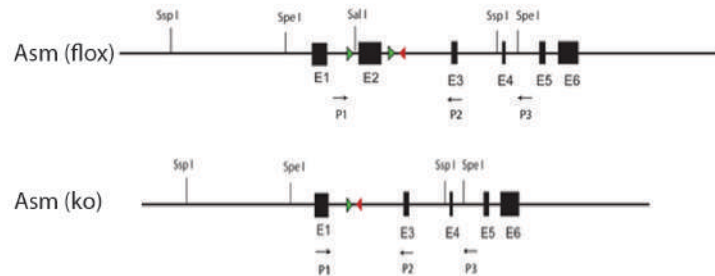

B. Loss of Purkinje neurons in cerebellum

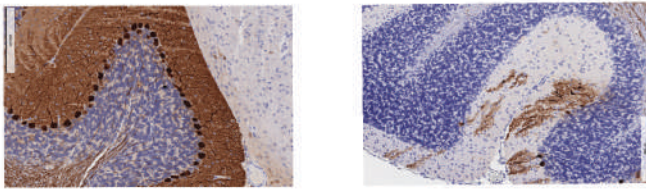

Purkinje neurons immunostained with D28K antibody.

D. ASM mutant MSCs failed to become bone-forming cells

Wild-type MSCs



ASM mutant MSCs



(*in vitro* differentiation assay, then stained with alizarin red)

C. Mesenchymal stem cells (MSCs) cultured from bones

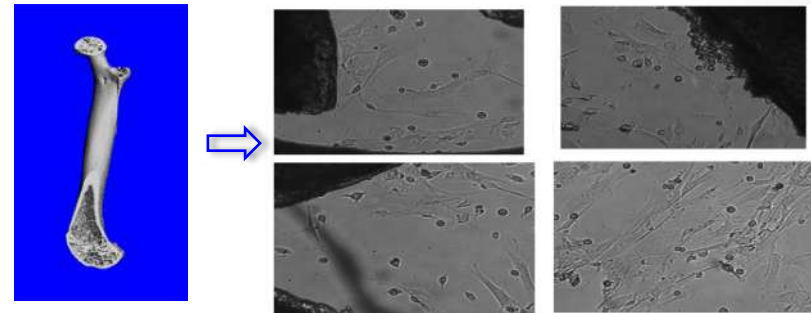

E. Potentials of MSCs for tissue repair

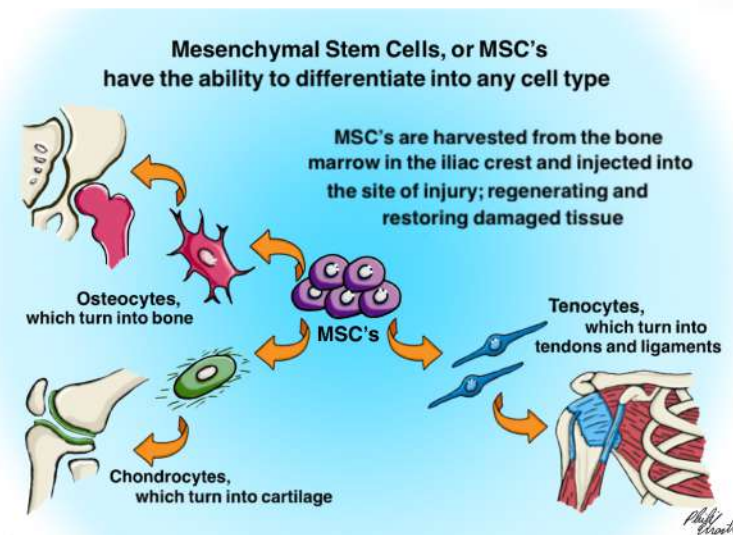

Stem Cells, Genetic and Epigenetic Inheritance, Cancer

Dr. Hui Zhang

Associate Professor

Department of Chemistry and Biochemistry

Phone: (702)774-1489

Email: hui.zhang@unlv.edu

Expertise:

- Biochemistry and developmental regulation of pluripotent embryonic stem cells, adult stem cells, and related diseases
- Regulation of chromatin structure, epigenetics, and transcription by protein methylation and ubiquitin enzymes
- DNA replication, DNA repair, cell cycle, genome instability, and cancer
- Targeting the vulnerability of human cancers

Current research areas in Zhang Laboratory:

- Discover novel proteins essential for stem cell regulation, examples:

How SOX2 is regulated in embryonic stem cells and many other stem cells in development?

- Sox2 is a master stem cell protein that controls the self-renewal and pluripotency of embryonic stem cells that can develop into any tissue types of cells in development.

- SOX2 is also a master regulator of many adult stem cells including the stem/progenitor cells for brain, lung, colon, breast, liver, cochlea/ear, skin, retina, ovary, bladder, esophagus, and testes for tissue repair/regeneration.

- Artificial Sox2 expression (together with Oct4 and accessory Klf4, and Myc) can virtually convert any differentiated cells, such as skin or blood cells, into induced pluripotent stem cells (iPSCs), the embryonic stem cell-like cells.

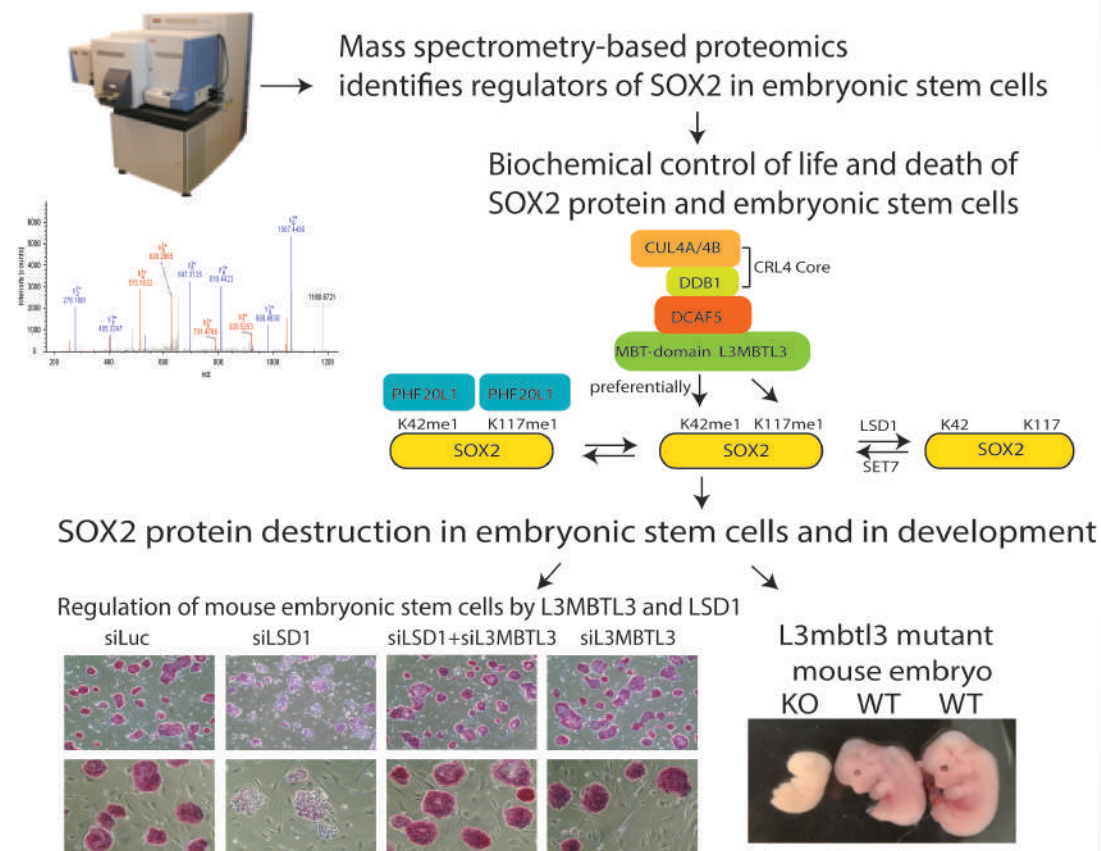

- Discover novel proteins important for epigenetic and cell cycle regulation, examples:
- Regulation of DNA replication and DNA methylation in normal and cancer cells**

- How DNA replicates only once in one cell cycle in animal cells? How re-replication is prevented that causes genome instability and cancer?

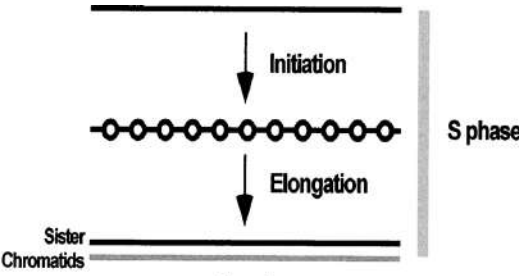

- How the fidelity of epigenetic DNA methylation is maintained during DNA replication?

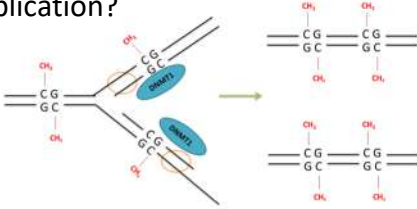

- Cancer Biology and therapy development**

Elevated SOX2 levels cause many cancers including cancers of lung, brain, breast, and ovary. These cancers are hard to treat because they behave like stem cells due to SOX2 expression. We are developing novel LSD1 chemical inhibitors that target the epigenetic vulnerability of these cancer cells.

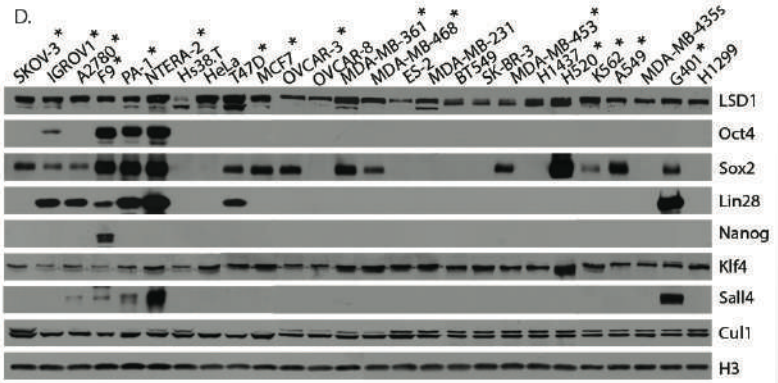
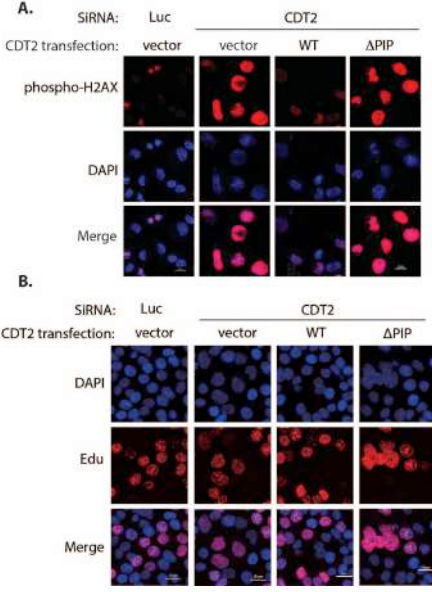
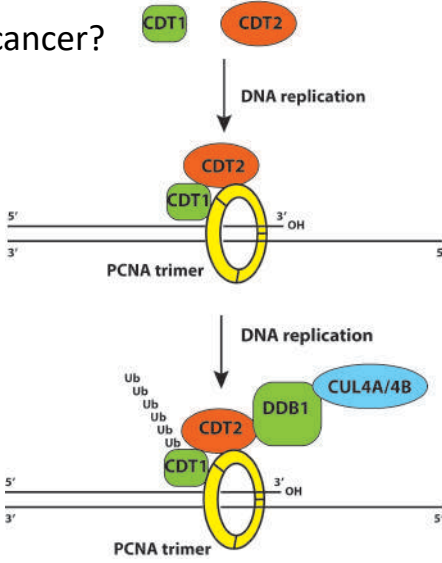

The presence of SOX2 in different types of cancer cells is responsible for sensitivity towards our LSD1 inhibitors. *: Sensitive to LSD1 Inhibitors